



*PRESENTS*

# Deluxe heat

## **SINGLE ZONE DUCTLESS OUTDOOR UNIT** Installation Manual

### **MODELS**

DHSZ109DA	9	kBtu/h
DHSZ112DA	12	kBtu/h
DHSZ118DA	18	kBtu/h
DHSZ124DA	24	kBtu/h



ECR International Inc.  
2201 Dwyer Avenue, Utica, NY 13501  
Tel. 800 325 5479  
[www.ecrinternational.com](http://www.ecrinternational.com)  
PN 615000258 REV. B [10/01/2021]

# CONTENTS

---

	PAGE
SAFETY PRECAUTIONS.....	3
OUTDOOR UNIT INSTALLATION.....	4
CLEARANCES.....	4
UNIT DIMENSIONS.....	6
ELECTRICAL DATA.....	7
REFRIGERANT PIPING REQUIREMENTS.....	9
AIR EVACUATION.....	13
ELECTRICAL AND GAS LEAK CHECKS.....	15
TEST RUN.....	16
DISPOSAL GUIDELINES.....	18
SPECIFICATIONS AND PERFORMANCE.....	19

All the illustrations and specifications in the manual are subject to change without prior notice for product improvement. The actual shape should prevail.



## WARNING

### ELECTRICAL SHOCK HAZARD!

Before installing, modifying, or servicing system, the main electrical disconnect switch must be in the OFF position. There may be more than 1 disconnect switch. Lock out and tag switch with a suitable warning label. Failure to follow these instructions could result in personal injury or death.

## CAUTION

### EQUIPMENT DAMAGE

Do not bury more than 36 in. (914 mm) of refrigerant pipe in the ground. If any section of pipe is buried, there must be a 6 in. (152 mm) vertical rise to the valve connections on the outdoor units. If more than the recommended length is buried, refrigerant may migrate to the cooler buried section during extended periods of system shutdown. This causes refrigerant slugging and could possibly damage the compressor at start-up.



## CAUTION

### LACERATION, BURN HAZARD

Laceration, burn hazard. Metal edges and parts may have sharp edges and/or may be hot. Use appropriate personal protection equipment to include safety glasses and gloves when installing or servicing this boiler. Failure to follow these instructions could result in minor or moderate injury.

## SAFETY CONSIDERATIONS :

Installing, starting up, and servicing air-conditioning equipment can be hazardous due to system pressures, electrical components, and equipment location (roofs, elevated structures, etc.).

Only trained, qualified installers and service mechanics should install, start-up, and service this equipment.

When installing or servicing the equipment, observe ALL precautions.

Follow all safety codes. Wear safety glasses and work gloves. Keep a quenching cloth and fire extinguisher nearby when brazing. Use care in handling, rigging, and setting bulky equipment.

Read these instructions thoroughly and follow all warnings or cautions included in literature and attached to the unit.

Consult local building codes and current editions of the National Electrical Code ( NEC ) NFPA 70. In Canada, refer to current editions of the Canadian electrical code CSA 22.1.

Recognize safety information. This is the safety-alert symbol. When you see this symbol on the unit and in instructions or manuals, be alert to the potential for personal injury. Understand these signal words: **DANGER**, **WARNING**, and **CAUTION**. These words are used with the safety-alert symbol.

**DANGER** identifies the most serious hazards which **will** result in severe personal injury or death.

**WARNING** signifies hazards which **could** result in personal injury or death.

**CAUTION** is used to identify unsafe practices which **may** result in minor personal injury or product and property damage.

**NOTE** is used to highlight suggestions which **will** result in enhanced installation, reliability, or operation.

# Outdoor Unit Installation

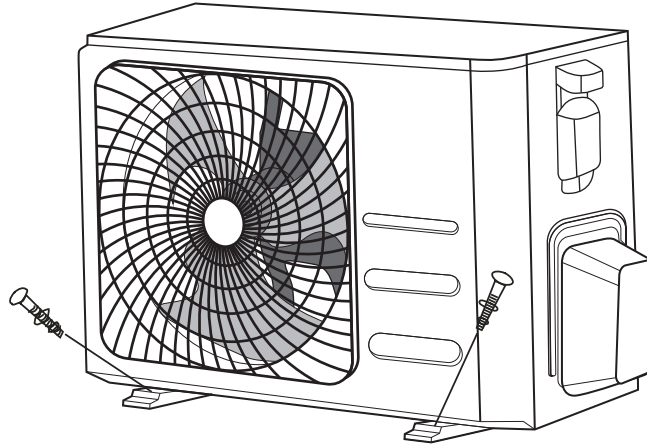

## Installation Instructions – Outdoor Unit

### Step 1: Select installation location

Before installing the outdoor unit, you must choose an appropriate location. The following are standards that will help you choose an appropriate location for the unit.

#### Proper installation locations meet the following standards:

- ☑ Meets all spatial requirements shown in Installation Space Requirements (**Fig. 4.1**)
- ☑ Good air circulation and ventilation
- ☑ Firm and solid—the location can support the unit and will not vibrate
- ☑ Noise from the unit will not disturb others
- ☑ Protected from prolonged periods of direct sunlight or rain

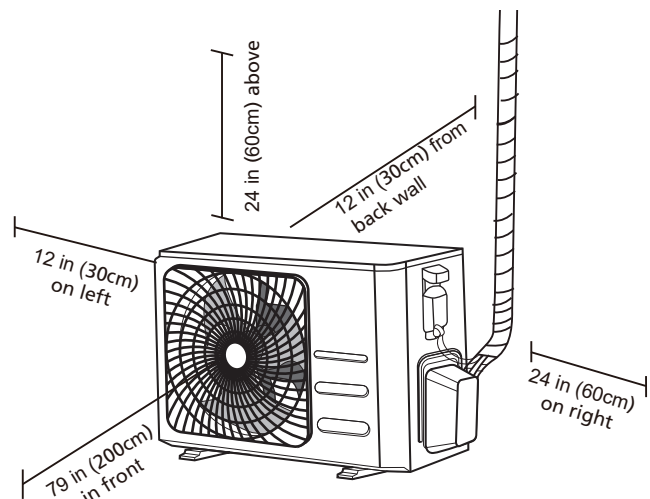

Fig. 4.1

#### **DO NOT** install unit in the following locations:

- ⊘ Near an obstacle that will block air inlets and outlets
- ⊘ Near a public street, crowded areas, or where noise from the unit will disturb others
- ⊘ Near animals or plants that will be harmed by hot air discharge
- ⊘ Near any source of combustible gas
- ⊘ In a location that is exposed to large amounts of dust
- ⊘ In a location exposed to a excessive amounts of salty air

## SPECIAL CONSIDERATIONS FOR EXTREME WEATHER

### If the unit is exposed to heavy wind:

Install unit so that air outlet fan is at a 90° angle to the direction of the wind. If needed, build a barrier in front of the unit to protect it from extremely heavy winds.

See **Fig. 4.2** and **Fig. 4.3** below.

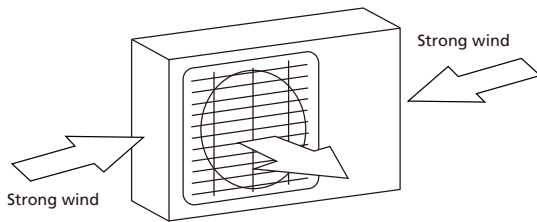

Fig. 4.2

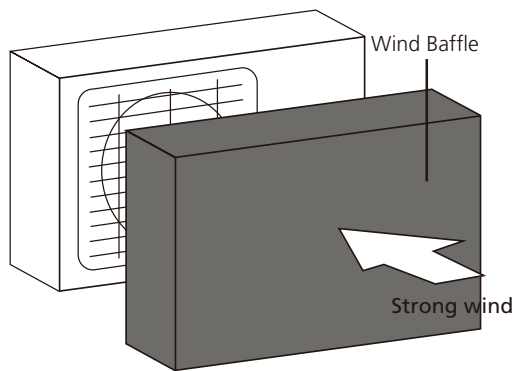

Fig. 4.3

### If the unit is frequently exposed to heavy rain or snow:

Build a shelter above the unit to protect it from the rain or snow. Be careful not to obstruct air flow around the unit.

### If the unit is frequently exposed to salty air (seaside):

Use outdoor unit that is specially designed to resist corrosion.

## Step 2: Install drain joint

Heat pump units require a drain joint. Before bolting the outdoor unit in place, you must install the drain joint at the bottom of the unit. Note that there are two different types of drain joints depending on the type of outdoor unit.

### If the drain joint comes with a rubber seal (see Fig. 4.4 - A), do the following:

1. Fit the rubber seal on the end of the drain joint that will connect to the outdoor unit.
2. Insert the drain joint into the hole in the base pan of the unit.
3. Rotate the drain joint 90° until it clicks in place facing the front of the unit.
4. Connect a drain hose extension (not included) to the drain joint to redirect water from the unit during heating mode.

### If the drain joint doesn't come with a rubber seal (see Fig. 4.4 - B), do the following:

1. Insert the drain joint into the hole in the base pan of the unit. The drain joint will click in place.
2. Connect a drain hose extension (not included) to the drain joint to redirect water from the unit during heating mode.

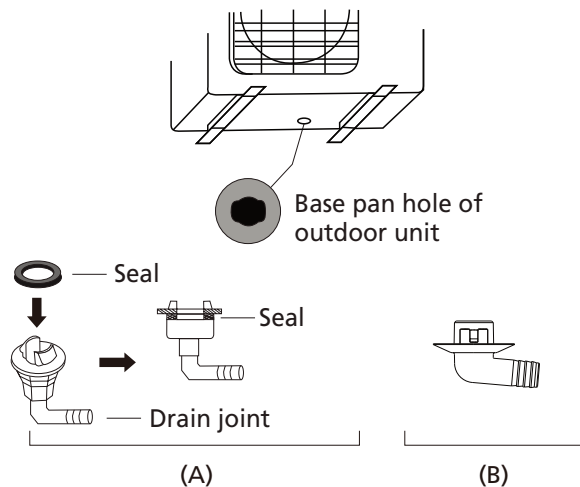

Fig. 4.4

## IN COLD CLIMATES

In cold climates, make sure that the drain hose is as vertical as possible to ensure swift water drainage. If water drains too slowly, it can freeze in the hose and flood the unit.

### Step 3: Anchor outdoor unit

The outdoor unit can be anchored to the ground or to a wall-mounted bracket.

#### UNIT MOUNTING DIMENSIONS

The following is a list of different outdoor unit sizes and the distance between their mounting feet. Prepare the installation base of the unit according to the dimensions below.

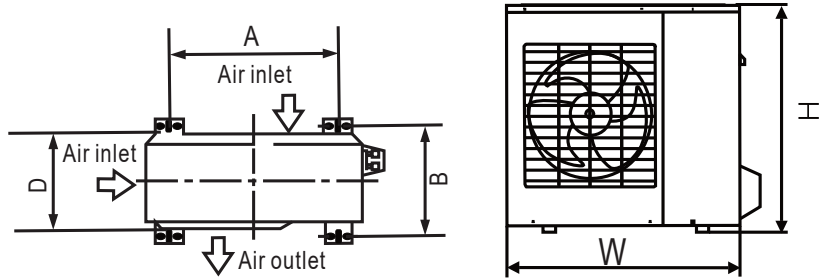

Fig. 4.5

Outdoor Unit Dimensions (mm) W x H x D	Mounting Dimensions	
	Distance A (mm)	Distance B (mm)
26.8"x17"x11.2" (681x434x285)	18.10" (460)	11.49" (292)
27.5"x21.6"x10.62" (700x550x270)	17.7"(450)	10.24" (260)
30.7"x21.25"x9.85" (780x540x250)	21.6" (549)	10.85" (276)
33.25"x27.5"x12.6" (845x700x320)	22" (560)	13.2" (335)
31.9"x22"x12.2" (810x558x310)	21.6" (549)	12.8" (325)
27.5"x21.6"x10.82" (700x550x275)	17.7"(450)	10.24" (260)
30.3"x21.85"x11.81" (770x555x300)	19.2" (487)	11.73" (298)
31.5"x21.8"x13.1"(800x554x333)	20.24" (514)	13.39" (340)
33.25"x27.63"x14.29"(845x702x363)	21.26" (540)	13.8" (350)
35.4"x33.85"x12.4" (900x860x315)	23.2" (590)	13.1" (333)
37.2"x31.9"x15.55"(945x810x395)	25.2" (640)	15.95" (405)
37.21"x31.9"x16.53" (946x810x420)	26.5" (673)	15.87" (403)
37.21"x31.9"x16.14" (946x810x410)	26.5" (673)	15.87" (403)

**If you install the unit on the ground or on a concrete mounting platform, do the following:**

1. Mark the positions for four expansion bolts based on dimensions in the Unit Mounting Dimensions chart.
2. Pre-drill holes for expansion bolts.
3. Clean concrete dust away from holes.
4. Place a nut on the end of each expansion bolt.
5. Hammer expansion bolts into the pre-drilled holes.

6. Remove the nuts from expansion bolts, and place outdoor unit on bolts.
7. Put washer on each expansion bolt, then replace the nuts.
8. Using a wrench, tighten each nut until snug.

**⚠ WARNING**

**WHEN DRILLING INTO CONCRETE, EYE PROTECTION IS RECOMMENDED AT ALL TIMES.**

If you install the unit on a wall-mounted bracket , do the following:

### ⚠ WARNING

Before installing a wall-mounted unit, make sure that the wall is made of solid brick, concrete, or of similarly strong material. **The wall must be able to support at least four times the weight of the unit.**

1. Mark the position of bracket holes based on dimensions in the Unit Mounting Dimensions chart.
2. Pre-drill the holes for the expansion bolts.
3. Clean dust and debris away from holes.
4. Place a washer and nut on the end of each expansion bolt.
5. Thread expansion bolts through holes in mounting brackets, put mounting brackets in position, and hammer expansion bolts into the wall.
6. Check that the mounting brackets are level.
7. Carefully lift unit and place its mounting feet on brackets.
8. Bolt the unit firmly to the brackets.

#### TO REDUCE VIBRATIONS OF WALL-MOUNTED UNIT

If allowed, you can install the wall-mounted unit with rubber gaskets to reduce vibrations and noise.

#### Step 4: Connect signal and power cables

The outside unit's terminal block is protected by an electrical wiring cover on the side of the unit. A comprehensive wiring diagram is printed on the inside of the wiring cover.

### ⚠ WARNING

1. All wiring must comply with local and national electrical codes, and must be installed by a licensed electrician.
2. All electrical connections must be made according to the Electrical Connection Diagram located on the side panels of the indoor and outdoor units.
3. If there is a serious safety issue with the power supply, stop work immediately. Explain your reasoning to the client, and refuse to install the unit until the safety issue is properly resolved.
4. Power voltage should be within 90-110% of rated voltage. Insufficient power supply can cause electrical shock or fire.
5. If connecting power to fixed wiring, install a surge protector and main power switch with a capacity of 1.5 times the maximum current of the unit.
6. If connecting power to fixed wiring, a switch or circuit breaker that disconnects all poles (**except unit ground**) and has a contact separation of at least 1/8in (3mm) must be incorporated in the fixed wiring. The qualified technician must use an approved circuit breaker or switch.
7. Only connect the unit to an individual branch circuit outlet. Do not connect another appliance to that outlet.
8. Make sure to properly ground the air conditioner **at all times**.
9. Every wire must be firmly connected. Loose wiring can cause the terminal to overheat, resulting in product malfunction and possible fire.
10. **Do not** let wires touch or rest against refrigerant tubing, the compressor, or any moving parts within the unit.
11. If the unit has an auxiliary electric heater, it must be installed at least 1 meter (40in) away from any combustible materials.

## ⚠ WARNING

**BEFORE PERFORMING ANY ELECTRICAL OR WIRING WORK, TURN OFF THE MAIN POWER TO THE SYSTEM.**

1. Prepare the cable for connection:

### USE THE RIGHT CABLE

- Indoor Power Cable (if applicable): H05VV-F or H05V2V2-F
- Outdoor Power Cable: H07RN-F
- Signal Cable: H07RN-F

### Minimum Cross-Sectional Area of Power and Signal Cables

#### North America

Appliance Amps (A)	AWG
18	14
25	12
30	10

#### Other Regions

Rated Current of Appliance (A)	Nominal Cross-Sectional Area (mm <sup>2</sup> )
> 3 and ≤ 6	0.75
> 6 and ≤ 10	1
> 10 and ≤ 16	1.5
> 16 and ≤ 25	2.5
> 25 and ≤ 32	4
> 32 and ≤ 40	6

- Using wire strippers, strip the rubber jacket from both ends of cable to reveal about 1.57in (40mm) of the wires inside.
- Strip the insulation from the ends of the wires.
- Using a wire crimper, crimp u-lugs on the ends of the wires.

## PAY ATTENTION TO LIVE WIRE

While crimping wires, make sure you clearly distinguish the Live ("L") Wire from other wires.

## ⚠ WARNING

**ALL WIRING MUST PERFORMED STRICTLY IN ACCORDANCE WITH THE WIRING DIRGRAM LOCATED INSIDE THE OUTDOOR UNIT'S WIRE COVER.**

- Unscrew the electrical wiring cover and remove it.
- Unscrew the cable clamp below the terminal block and place it to the side.
- Match the wire colors/labels with the labels on the terminal block, and firmly screw the u-lug of each wire to its corresponding terminal.
- After checking to make sure every connection is secure, loop the wires around to prevent rain water from flowing into the terminal.
- Using the cable clamp, fasten the cable to the unit. Screw the cable clamp down tightly.
- Insulate unused wires with PVC electrical tape. Arrange them so that they do not touch any electrical or metal parts.
- Replace the wire cover on the side of the unit, and screw it in place.

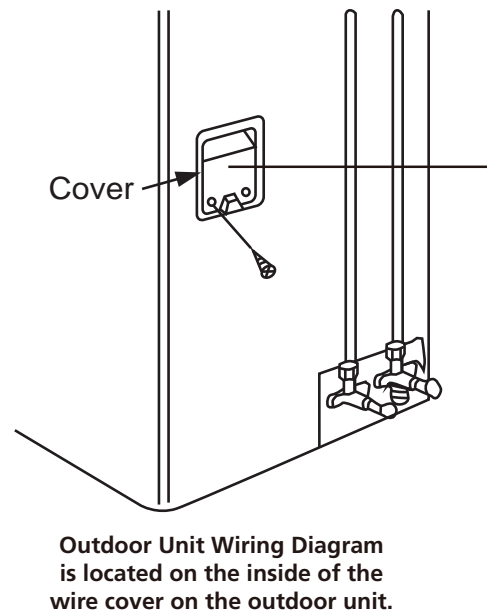
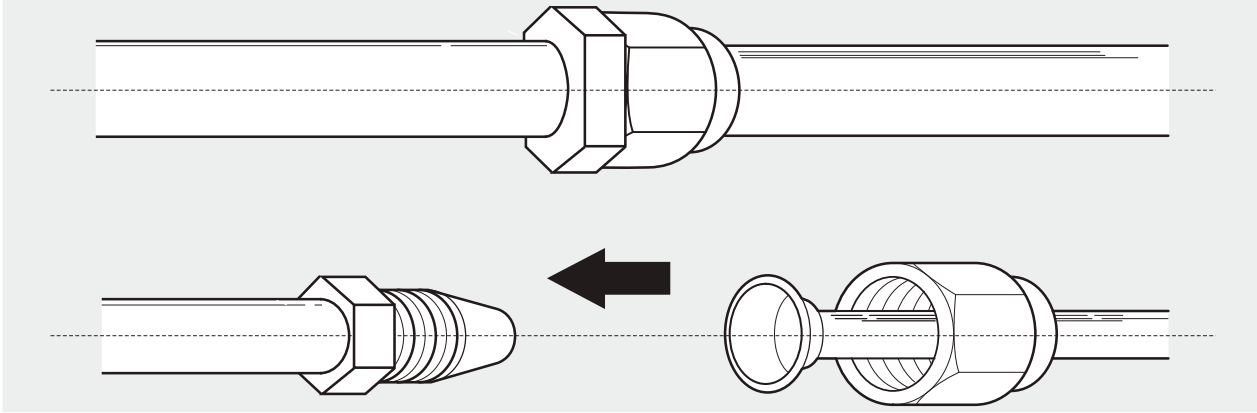

Fig. 4.6



# Refrigerant Piping Connection



## Note on Pipe Length

The length of refrigerant piping will affect the performance and energy efficiency of the unit. Nominal efficiency is tested on units with a pipe length of 16.5ft (5 m), in North America, the standard pipe length is 25ft (7.5 m). A minimum pipe run of 9.9 ft. (3m) is required to minimize vibration & excessive noise. Install correct size flare nut onto the tubing for a 45° flare connection. Refer to the table below for specifications on the maximum length and drop height of piping.

**Maximum Length and Drop Height of Refrigerant Piping per Unit Model**

Model	Capacity (BTU/h)	Max. Length	Max. Drop Height
R410A Inverter Split Air Conditioner	< 15,000	82 ft (25 m)	33ft (10 m)
	≥ 15,000 and < 24,000	98.5 ft (30 m)	66 ft (20 m)
	≥ 24,000 and < 36,000	164 ft (50 m)	82 ft (25 m)

## Connection Instructions – Refrigerant Piping

### Step 1: Cut pipes

When preparing refrigerant pipes, take extra care to cut and flare them properly. This will ensure efficient operation and minimize the need for future maintenance.

1. Measure the distance between the indoor and outdoor units.

- Using a pipe cutter, cut the pipe a little longer than the measured distance.
- Make sure that the pipe is cut at a perfect 90° angle. Refer to **Fig. 5.1** for bad cut examples.

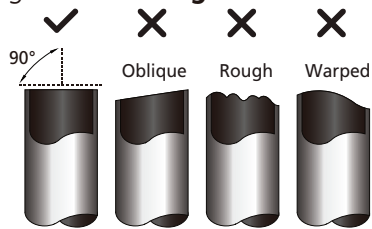

Fig. 5.1

### DO NOT DEFORM PIPE WHILE CUTTING

Be extra careful not to damage, dent, or deform the pipe while cutting. This will drastically reduce the heating efficiency of the unit.

### Step 2: Remove burrs

Burrs can affect the air-tight seal of refrigerant piping connection. They must be completely removed.

- Hold the pipe at a downward angle to prevent burrs from falling into the pipe.
- Using a reamer or deburring tool, remove all burrs from the cut section of the pipe.
- Be sure to clean and remove all filings and debris from the pipe.

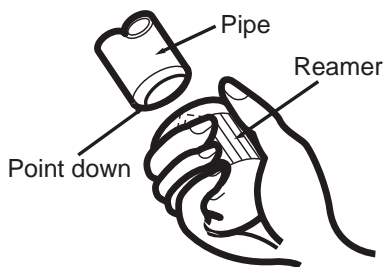

Fig. 5.2

### Step 3: Flare pipe ends

Proper flaring is essential to achieve an airtight seal.

- After removing burrs from cut pipe, seal the ends with PVC tape to prevent foreign materials from entering the pipe.
- Sheath the pipe with insulating material.
- Place flare nuts on both ends of pipe. Make sure they are facing in the right direction, because you can't put them on or change their direction after flaring. See **Fig. 5.3**

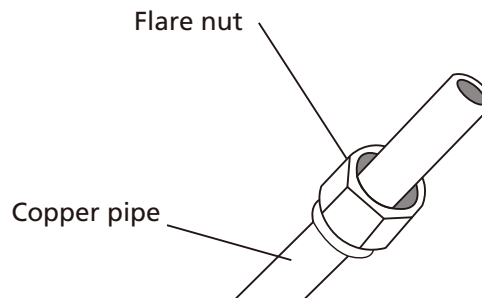

Fig. 5.3

- Remove PVC tape from ends of pipe when ready to perform flaring work for a 45° flare.
- Clamp flare form on the end of the pipe. The end of the pipe must extend beyond the edge of the flare form in accordance with the dimensions shown in the table below.

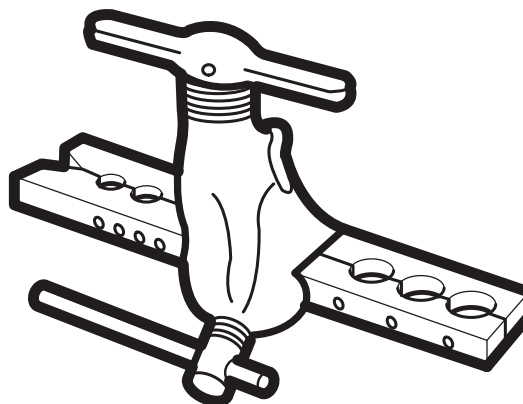

Fig. 5.4

### PIPING EXTENSION BEYOND FLARE FORM

Outer Diameter of Pipe	A	
	Min.	Max.
Ø 0.25" (Ø 6.35mm)	0.0275" (0.7mm)	0.05" (1.3mm)
Ø 0.375" (Ø 9.52mm)	0.04" (1.0mm)	0.063" (1.6mm)
Ø 0.5" (Ø 12.7mm)	0.04" (1.0mm)	0.07" (1.8mm)
Ø 0.63" (Ø 16mm)	0.078" (2.0mm)	0.086" (2.2mm)
Ø 0.75" (Ø 19 mm)	0.078" (2.0mm)	0.094" (2.4mm)

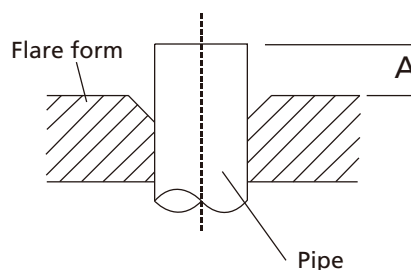

Fig. 5.5

- Place flaring tool onto the form.
- Turn the handle of the flaring tool clockwise until the pipe is fully flared.
- Remove the flaring tool and flare form, then inspect the end of the pipe for cracks and even flaring.

#### Step 4: Connect pipes

When connecting refrigerant pipes, be careful not to use excessive torque or to deform the piping in any way. You should first connect the low-pressure pipe, then the high-pressure pipe.

#### MINIMUM BEND RADIUS

When bending connective refrigerant piping, the minimum bending radius is 4 in. (10cm). See Fig. 5.6

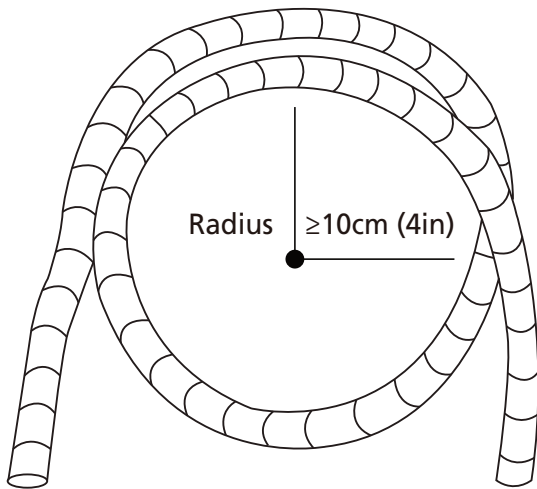

Fig. 5.6

#### Instructions for Connecting Piping to Indoor Unit

- Align the center of the two pipes that you will connect making a 45° flare connection. See Fig. 5.7.

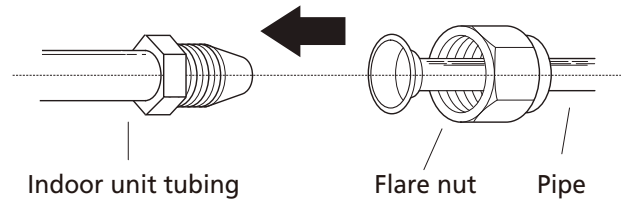

Fig. 5.7

- Tighten the flare nut as tightly as possible by hand.
- Using a spanner, grip the nut on the unit tubing.
- While firmly gripping the nut on the unit tubing, use a torque wrench to tighten the flare nut according to the torque values in the **Torque Requirements** table below. Loosen the flaring nut slightly, then tighten again.

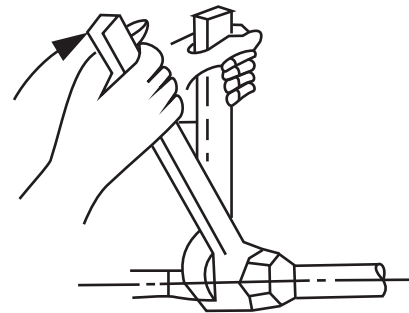

Fig. 5.8

#### TORQUE REQUIREMENTS

Outer Diameter of Pipe	Tightening Torque	Add. Tightening Torque
Ø 0.25" (Ø 6.35mm)	11lb•ft (1500 N•cm)	11.8lb•ft (1600N•cm)
Ø 0.375" (Ø 9.52mm)	18.4lb•ft (2,500 N•cm)	19.18lb•ft (2600N•cm)
Ø 0.5" (Ø 12.7mm)	25.8lb•ft (3500 N•cm)	26.55lb•ft (3,600 N•cm)
Ø 0.63"1 (Ø 6mm)	33.19lb•ft (4500 N•cm)	34.67lb•ft (4,700 N•cm)
Ø 0.75" (Ø 19mm)	47.94lb•ft (6500 N•cm)	49.42lb•ft (6,700 N•cm)

#### DO NOT USE EXCESSIVE TORQUE

Excessive force can break the nut or damage the refrigerant piping. You must not exceed torque requirements shown in the table above.

## Instructions for Connecting Piping to Outdoor Unit

1. Unscrew the cover from the packed valve on the side of the outdoor unit. (See **Fig. 5.9**)

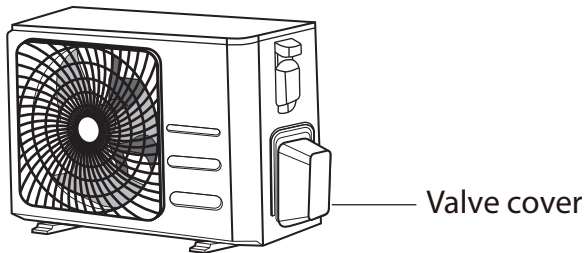
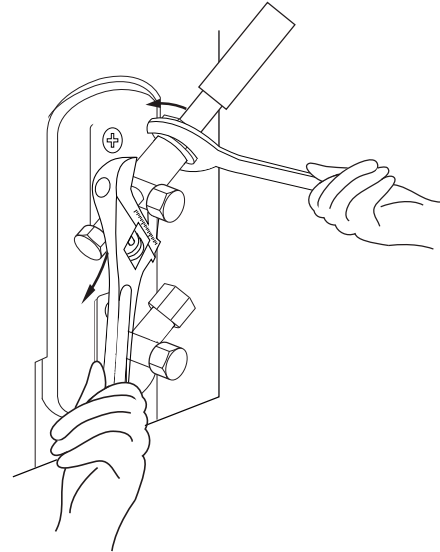

**Fig. 5.9**

2. Remove protective caps from ends of valves.
3. Align flared pipe end with each valve, and tighten the flare nut as tightly as possible by hand.
4. Using a spanner, grip the body of the valve. Do not grip the nut that seals the service valve. (See **Fig. 5.10**)

## USE SPANNER TO GRIP MAIN BODY OF VALVE

Torque from tightening the flare nut can snap off other parts of valve.



**Fig. 5.10**

5. While firmly gripping the body of the valve, use a torque wrench to tighten the flare nut according to the correct torque values.
6. Loosen the flaring nut slightly, then tighten again.
7. Repeat Steps 3 to 6 for the remaining pipe.

# Air Evacuation

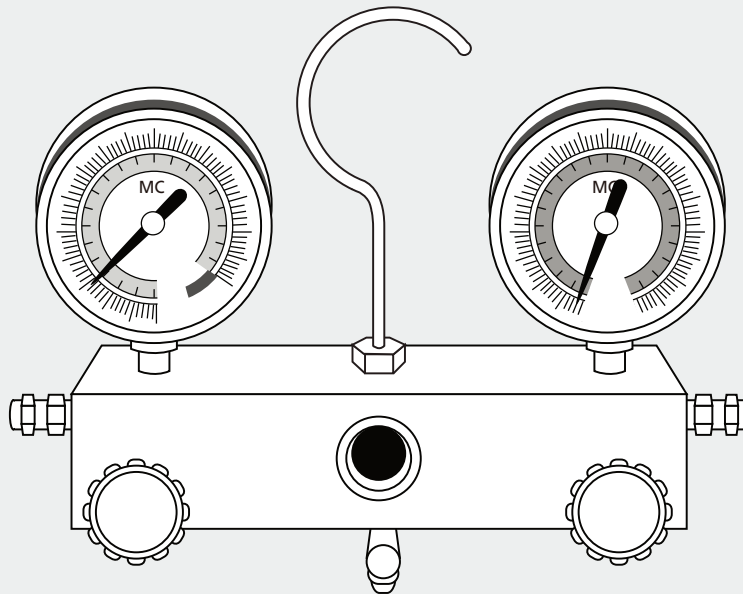

## Preparations and Precautions

Air and foreign matter in the refrigerant circuit can cause abnormal rises in pressure, which can damage the air conditioner, reduce its efficiency, and cause injury. Use a vacuum pump and manifold gauge to evacuate the refrigerant circuit, removing any non-condensable gas and moisture from the system.

Evacuation should be performed upon initial installation and when unit is relocated.

### BEFORE PERFORMING EVACUATION

- ☑ Check to make sure that both high-pressure and low-pressure pipes between the indoor and outdoor units are connected properly in accordance with the Refrigerant Piping Connection section of this manual.
- ☑ Check to make sure all wiring is connected properly.

## Evacuation Instructions

Before using the manifold gauge and vacuum pump, read their operation manuals to familiarize yourself with how to use them properly.

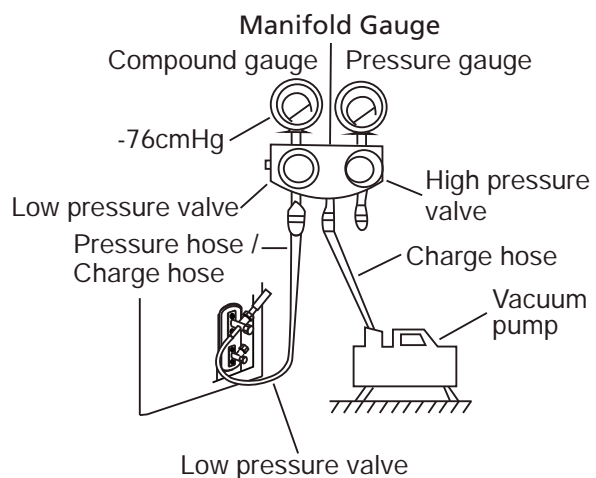
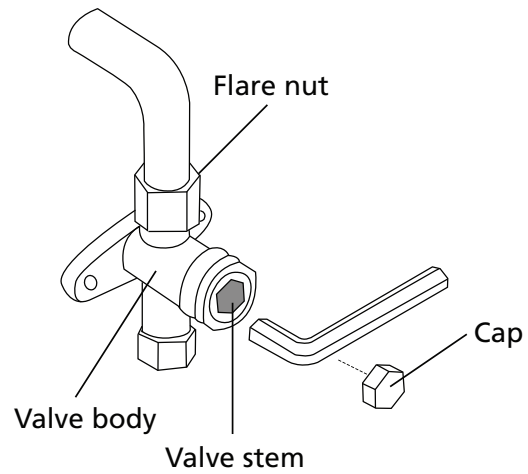

Fig. 6.1

1. Connect the charge hose of the manifold gauge to service port on the outdoor unit's low pressure valve.
2. Connect another charge hose from the manifold gauge to the vacuum pump.

3. Open the Low Pressure side of the manifold gauge. Keep the High Pressure side closed.
4. Turn on the vacuum pump to evacuate the system.
5. Run the vacuum for at least 15 minutes, or until the Micron gage reads 500 microns or less.
6. Close the Low Pressure side of the manifold gauge, and turn off the vacuum pump.
7. Wait for 5 minutes, then check that there has been no change in system pressure.
8. If there is a change in system pressure, refer to Gas Leak Check section for information on how to check for leaks. If there is no change in system pressure, unscrew the cap from the packed valve (high pressure valve).
9. Insert hexagonal wrench into the packed valve (high pressure valve) and open the valve by turning the wrench in a 1/4 counterclockwise turn. Listen for gas to exit the system, then close the valve after 5 seconds.
10. Watch the Pressure Gauge for one minute to make sure that there is no change in pressure. The Pressure Gauge should read slightly higher than atmospheric pressure.



**Fig. 6.2**

11. Remove the charge hose from the service port.
12. Using hexagonal wrench, fully open both the high pressure and low pressure valves.
13. Tighten valve caps on all three valves (service port, high pressure, low pressure) by hand. You may tighten it further using a torque wrench if needed.

### OPEN VALVE STEMS GENTLY

When opening valve stems, turn the hexagonal wrench until it hits against the stopper. Do not try to force the valve to open further.

### Note on Adding Refrigerant

Some systems require additional charging depending on pipe lengths. The standard pipe length is 25ft (7.5m). The additional refrigerant to be charged can be calculated using the following formula:

#### ADDITIONAL REFRIGERANT PER PIPE LENGTH

Connective Pipe Length (m)	Air Purging Method	Additional Refrigerant	
≤ Standard pipe length	Vacuum Pump	N/A	
> Standard pipe length	Vacuum Pump	Fluid Side: Ø 0.25" (Ø 6.35mm)  <b>Inverter R410A:</b> (Pipe length – standard length) x 0.16oz/ft (Pipe length – standard length) x 15g/m	Liquid Side: Ø 0.375" (Ø 9.52mm)  <b>Inverter R410A:</b> (Pipe length – standard length) x 0.32oz/ft (Pipe length – standard length) x 30g/m

Air Evacuation

## ⚠ WARNING

**DO NOT** mix refrigerant types.

# Electrical and Gas Leak Checks

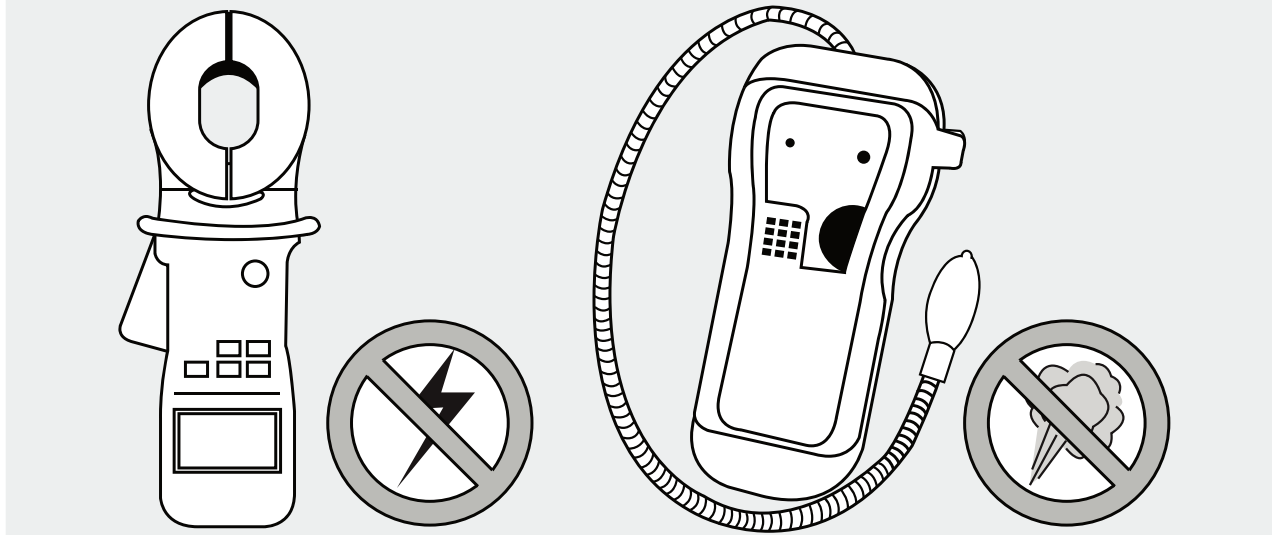

## Electrical Safety Checks

After installation, confirm that all electrical wiring is installed in accordance with local and national regulations, and according to the Installation Manual.

### BEFORE TEST RUN

#### Check Grounding Work

Measure grounding resistance by visual detection and with grounding resistance tester. Grounding resistance must be less than  $0.1\Omega$ .

**Note:** This may not be required for some locations in the US.

### DURING TEST RUN

#### Check for Electrical Leakage

During the **Test Run**, use an electroprobe and multimeter to perform a comprehensive electrical leakage test.

If electrical leakage is detected, turn off the unit immediately and call a licensed electrician to find and resolve the cause of the leakage.

**Note:** This may not be required for some locations in the US.

## ⚠ WARNING

**ELECTRIC SHOCK HAZARD! ALL WIRING SHALL COMPLY WITH THE NATIONAL ELECTRICAL CODES, AND SHALL BE INSTALLED BY A LICENSED ELECTRICIAN.**

## Gas Leak Checks

There are two different methods to check for gas leaks.

### Soap and Water Method

Using a soft brush, apply soapy water or liquid detergent to all pipe connection points on the indoor unit and outdoor unit. The presence of bubbles indicates a leak.

### Leak Detector Method

If using leak detector, refer to the device's operation manual for proper usage instructions.

## AFTER PERFORMING GAS LEAK CHECKS

After confirming that the all pipe connection points DO NOT leak, replace the valve cover on the outside unit.

# Test Run

## Before Test Run

Only perform test run after you have completed the following steps:

- **Electrical Safety Checks** – Confirm that the unit’s electrical system is safe and operating properly
- **Gas Leak Checks**– Check all flare nut connections and confirm that the system is not leaking
- Confirm that gas and liquid (high and low pressure) valves are fully open

## Test Run Instructions

You should perform the **Test Run** for at least 30 minutes.

1. Connect power to the unit.
2. Press the **ON/OFF** button on the remote controller to turn it on.
3. Press the **MODE** button to scroll through the following functions, one at a time:
  - COOL – Select lowest possible temperature
  - HEAT – Select highest possible temperature
4. Let each function run for 5 minutes, and perform the following checks:

List of Checks to Perform	PASS/FAIL	
No electrical leakage		
Unit is properly grounded		
All electrical terminals properly covered		
Indoor and outdoor units are solidly installed		
All pipe connection points do not leak	Outdoor (2):	Indoor (2):
Water drains properly from drain hose		
All piping is properly insulated		
Unit performs COOL function properly		
Unit performs HEAT function properly		
Indoor unit louvers rotate properly		
Indoor unit responds to remote controller		



## DOUBLE-CHECK PIPE CONNECTIONS

During operation, the pressure of the refrigerant circuit will increase. This may reveal leaks that were not present during your initial leak check. Take time during the Test Run to double-check that all refrigerant pipe connection points do not have leaks. Refer to **Gas Leak Check** section for instructions.

5. After the Test Run is successfully completed, and you confirm that all checks points in List of Checks to Perform have PASSED, do the following:
  - a. Using remote control, return unit to normal operating temperature.
  - b. Using insulation tape, wrap the indoor refrigerant pipe connections that you left uncovered during the indoor unit installation process.

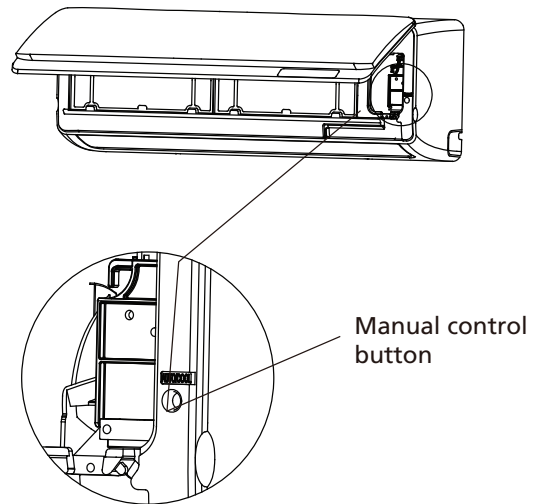

Fig. 8.1

## IF AMBIENT TEMPERATURE IS BELOW 63°F (17°C)

You can't use the remote controller to turn on the COOL function when the ambient temperature is below 63°F (17°C). In this instance, you can use the **MANUAL CONTROL** button to test the COOL function.

1. Lift the front panel of the indoor unit, and raise it until it clicks in place.
2. The **MANUAL CONTROL** button is located on the right-hand side of the unit. Press it 2 times to select the COOL function. See **Fig.8.1**
3. Perform Test Run as normal.

# Disposal Guidelines

This appliance contains refrigerant and other potentially hazardous materials. When disposing of this appliance, the law requires special collection and treatment. **Do not** dispose of this product as household waste or unsorted municipal waste.

When disposing of this appliance, you have the following options:

- Dispose of the appliance at designated municipal electronic waste collection facility.
- Sell the appliance to certified scrap metal dealers.

## Special notice

Disposing of this appliance in the forest or other natural surroundings endangers your health and is bad for the environment. Hazardous substances may leak into the ground water and enter the food chain.

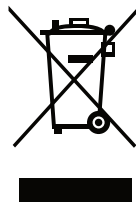

# SPECIFICATIONS AND PERFORMANCE

Outdoor Condensing Unit model			DHSZ109DA	DHSZ112DA	DHSZ118DA	DHSZ124DA
Power supply		Ph-V-Hz	208-230V~ 60Hz, 1Ph	208-230V~ 60Hz, 1Ph	208-230V~ 60Hz, 1Ph	208-230V~ 60Hz, 1Ph
Cooling	Capacity	Btu/h	9000	12000	17000	24000
	Input	W	620	960	1360	1920
	Rated current	A	2.7	4.2	5.95	8.4
	EER	Btu/w	14.5	13	12.5	13
	SEER	Btu/w	25	22.5	20	20.5
Heating	Capacity	Btu/h	10900	12000	18000	24000
	Input	W	835	975	1685	2500
	Rated current	A	3.6	4.2	7.4	10.9
	COP	W/W	3.83	3.55	3.13	2.81
	HSPF4	Btu/w	11.2	12	10.3	11.5
	HSPF5	Btu/w	9	9.9	8.8	9.6
MINIMUM CIRCUIT AMPACITY		A	9	9	18	20
MAX TIME DELAY FUSE OR HARC BREAKER		A	15	15	25	30
Outdoor air flow		m <sup>3</sup> /h	1900	2000	2300	4000
Outdoor air flow		cfm	1120	1180	1355	2355
Outdoor noise level		dB(A)	55.5	56	57.5	60
Outdoor unit	Dimension(W*D*H)	mm	800x333x554	800x333x554	845x363x702	946x410x810
	Dimension(W*D*H)	inch	31.50x13.11x21.81	31.50x13.11x21.81	33.27x14.29x27.64	37.24/16.14/31.89
	Packing (W*D*H)	mm	920x390x615	920x390x615	965x395x755	1090x500x875
	Packing (W*D*H)	inch	36.22x15.35x24.21	36.22x15.35x24.21	37.99x15.55x29.72	42.91x19.69x34.45
	Net/Gross weight	kg	40 / 42.5	40 / 42.5	48.7/52.2	61.5/67.5
	Net/Gross weight	lbs.	88.2/93.7	88.2/93.7	107.4/115.1	135.58/148.81
Refrigerant type 410A/oz		oz	52.9	52.9	68.8	91.7
Refrigerant precharge (total pipe length)		ft	25	25	25	25
Additional charge for each ft		oz	0.161	0.161	0.161	0.322
Design pressure		psig	550/340 psig	550/340 psig	550/340 psig	550/340 psig
Refrigerant piping	Liquid side/ Gas side	inch / mm	1/4" liquid line / 3/8" gas line Φ6.35 mm liquid / Φ9.52 mm gas	1/4" liquid line / 1/2" gas line Φ6.35 mm liquid / Φ12.7 mm gas	1/4" liquid line / 1/2" gas line Φ6.35 mm liquid / Φ12.7 mm gas	3/8" liquid line / 5/8" gas line Φ9.52 mm liquid / Φ15.9 mm gas
	Max. refrigerant pipe length	m	25	25	30	50
	Max. refrigerant pipe length	ft	82	82	98	164
	Max. difference in level	m	10	10	20	25
	Max. difference in level	ft	33	33	66	82
Operating Range Ambient temperature	Indoor(cooling/ heating)	°C	17~32/0~30	17~32/0~30	17~32/0~30	17~32/0~30
	Indoor(cooling/ heating)	°F	62~90/32~86	62~90/32~86	62~90/32~86	62~90/32~86
	Outdoor(cooling/heating)	°C	-30~-50/-30~30	-30~-50/-30~30	-30~-50/-30~30	-30~-50/-30~30
	Outdoor(cooling/heating)	°F	-22~-122/-22~86	-22~-122/-22~86	-22~-122/-22~86	-22~-122/-22~86

**Additional Refrigerant Calculation :** Sum Total Liquid Pipe ft. (m) - Additional Charge Required After ft. (m.) x Additional Charge oz./ft. (g/m) 0.16 (15)

## NOTES:

If the calculation results in a negative number no refrigerant is required to be added or removed.

Electronic expansion valves in the outdoor unit are used as metering devices

**NOTE:** The refrigerant charge included is adequate for the outdoor unit's maximum number of zones multiplied by the standard piping length per zone. For piping runs greater than the "Maximum Piping Length with no additional refrigerant charge per System", see Additional Refrigerant Charge (see Table 3).

## Refrigerant Piping:

Line sets to be sized based on the connection size of the indoor unit. Each pipe should be insulated individually.



2201 Dwyer Avenue, Utica, NY 13501  
Tel. 800 325 5479  
[www.ecrinternational.com](http://www.ecrinternational.com)

All specifications subject to change without notice.  
©2021 ECR International, Inc.