



Comfort Where It Counts.

CAH12-C2C09P

Rev. 1.0 [1/05]

JOB NAME: _____ LOCATION: _____
PURCHASER: _____
ENGINEER: _____
SUBMITTED TO: _____ FOR: REFERENCE [] APPROVAL [] CONSTRUCTION []
SUBMITTED BY: _____ DATE: _____
UNIT DESIGNATION: SCHEDULE #: _____ MODEL #: _____

▲▼CAPACITIES

Cooling 9,000 Btu

Indoor Design Temp °F DB/WB
Cooling 80/67

Outdoor Design Temp °F DB/WB
Cooling 95/75

EER 12.3
SEER 13.0

▲▼INDOOR UNIT

Power Supply 208/230/1/60
Max. Fuse Size 15 Amps
(w/1.5KW Electric Heat)
Min. Ampacity 8.7 Amps
(w/1.5KW Electric Heat)
Sound 39 dB(A) High
35 dB(A) Low
Weight 80 Lbs.

▲▼OUTDOOR UNIT

Power Supply 208/230/1/60
Max. Fuse Size 15 Amps
Min. Ampacity 4.9 Amps
Sound 61 dB(a)
Weight 105 Lbs.

▲▼REFRIGERANT PIPING

Max. Lift 25 Ft.
Max. Total Interconnect 50 Ft.
Liquid (OD) 1/4 In.
Suction (OD) 1/2 In.

▲▼STANDARD FEATURES

- Five-Year Compressor/One-Year Parts Warranty
- Anti-Short Cycle Protection
- Fan Purge
- Side Discharge/ Vertically Arranged Condenser
- Condensate Pump w/18" Lift
- Fresh Air Knockouts For Outside Fresh Air Intake
- Branch Duct Knockouts For Remote Discharging
- "Duratec" Performance Package For Compressor Protection
 - Suction Accumulator
 - Filter Dryer
 - Loss Of Charge Switch

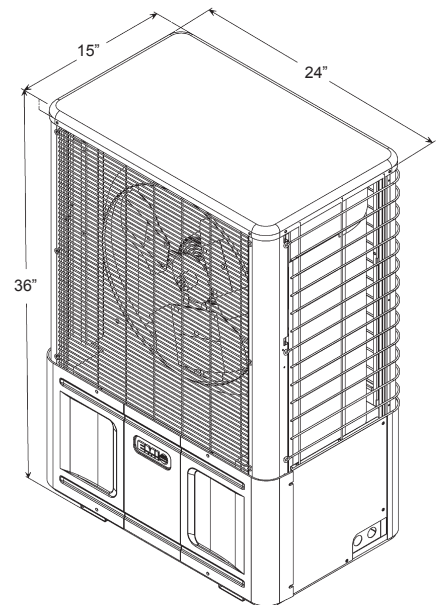
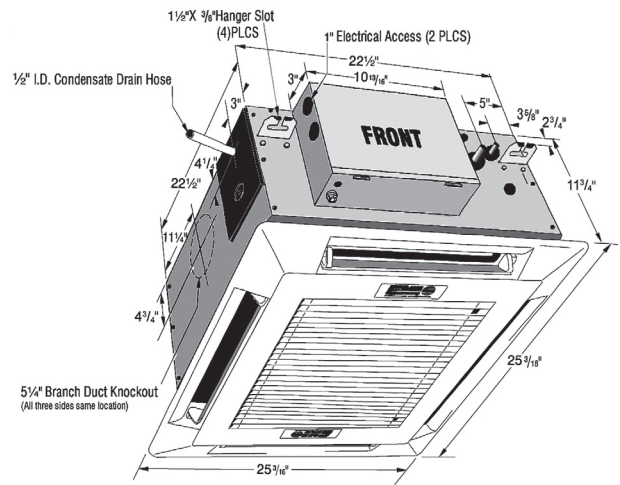

EMI ENGINEERING SUBMITTAL

▲▼ PART ONE- "GENERAL"

The Straight Cool air conditioning system shall be an EMI AmericaSeries split system. The system shall consist of a cassette ceiling mounted packaged evaporator section Model CAH12 and matching AmericaSeries outdoor unit Model C2C09P. The units shall be made within North America. The units shall be listed by Intertek Testing Service (ITS) and bear the ETL label. All wiring shall be in accordance with the National Electrical Code (N.E.C.). The units shall be rated in accordance with ARI Standard 210/240. The units shall be manufactured in a facility certified to ISO 9001, which is an international standard used to provide guidance in the development and implementation of an effective Quality Management System. The condensing unit shall contain an R-22 refrigerant charge for the evaporator section and condenser section. System SEER shall meet or exceed 2006 Federal Standards.

▲▼ PART TWO- "WARRANTY"

The units shall have a manufacturer's warranty for a period of one (1) year from date of installation. The compressor shall have a warranty of five (5) years from date of installation. If, during this period, any part should fail to function properly due to defects in workmanship or material, it shall be replaced or repaired at the discretion of Enviromaster International LLC. This warranty does not include labor. Manufacturer shall have fifteen years experience in the U.S. market.

▲▼ PART THREE- "PERFORMANCE"

Each indoor unit shall provide a total minimum cooling capacity of 9,000 Btuh with a SEER of 13.0 and an EER of 12.3 at ARI standard conditions. The system net minimum total cooling capacity shall be 9,000 Btuh and the net minimum sensible cooling capacity shall be 6,900 Btuh with a circulating air rate of 340 CFM at 80° F (DB) / 67° F (WB) entering the indoor coil and 95° F (DB) air entering the outdoor coil. The total power consumption of the combined system shall not exceed 735 Watts at these conditions.

▲▼ PART FOUR- "INDOOR UNIT"

The indoor unit shall be factory assembled wired and contain a low voltage transformer. The indoor unit shall consist of galvanized steel chassis with fire-resistant thermal and acoustic foam insulation and pearl grey high-impact polystyrene fascia. This unit shall fit in the ceiling and have the capability of attaching a branch supply duct as well as a fresh air duct. The evaporator fan shall be backward curved impeller centrifugal design, dynamically and statically balanced, and mounted on integral mounting rails. The evaporator motor shall be multispeed, enclosed type with thermal protection and sealed lifetime bearings. The indoor unit shall have factory installed 1.5 KW electric heat. The indoor unit shall be equipped with an orifice piston in the evaporator and shall have 4-way adjustable air supply louvers. Return air shall be filtered by means of an easily removable filter. The evaporator coil shall be of nonferrous construction with louvered fins bonded to rifled copper tubing. The tubing shall have inner grooves for high efficiency heat exchange. All tube joints shall be brazed with phosphor copper or silver alloy. The coil shall be pressure tested at the factory. A condensate pan and drain shall be provided under the coil. An integral condensate pump capable of lifting 18 inches shall be provided. The unit electrical power shall be 208/230 Volts, 1 phase, 60 Hertz. The system shall be capable of satisfactory operation within voltage limits of 208/230 +/- 10% Volts.

▲▼ PART FIVE- "CONTROL SYSTEM"

The control system shall consist of connections for a 24V Wall Thermostat Control; anti-short cycle compressor protection; fan purge; 60 second post-purge fan relay after heat/cool call is dropped (for improved efficiency); integral heating relay to ensure that the fan operates whenever electric heat is energized; and two-stage heating capability when matched up with an EMI heat pump and an appropriate two stage thermostat. Wiring shall run from indoor unit to the 24V wall thermostat and to outdoor unit with **NO SPLICES**. When running low voltage wiring, a double insulated 18 awg wire should be used. The control voltage between the indoor unit and the outdoor unit shall be 24 Volts A.C. The 24 Volts shall be generated from the indoor unit's 24 Volt 40VA transformer.

▲▼ **PART SIX- "OUTDOOR UNIT"**

The outdoor unit shall be completely factory assembled, piped and wired. The cabinet shall be fabricated of 18 and 20 gauge aluminized steel, finished in "off-white" with corrosion inhibiting polyester powder-coated paint (2000 hour salt spray tested), and a black scratch and dent resistant injection molded front access panel. The unit shall be furnished with one (1) large diameter, direct drive, high efficiency, three blade, propeller type fan. The motor shall be PSC type with internal overload protection, and shall be the permanently lubricated type, and resiliently mounted for quiet operation. The fan shall be provided with a guard to prevent contact with moving parts. The compressor shall be of the high-performance rotary type with Duratec package which consists of an oversized accumulator, factory installed solid core filter and thermal overloads. The compressor shall be mounted so as to avoid the transmission of vibration. The condenser shall have easy access hose connections at 45° from valve body. The refrigeration system shall be equipped with loss of charge switch, and have the capability to operate with a maximum height difference of 25 feet and overall refrigerant tubing length of 50 feet between indoor and outdoor sections without the need for line size changes or additional oil. The condenser coil shall be U-shaped and protected by a wire coil guard. Construction is seamless copper tubing with enhanced aluminum fins. The tubes are mechanically expanded for secure bonding to fin shoulder. The unit shall be controlled by the microprocessor located in the indoor matching unit. The unit electrical power shall be 208/230 Volts, 1 phase, 60 Hertz. The system shall be capable of satisfactory operation within voltage limits of 208/230 Volts +/- 10%.

▲▼ **PART SEVEN- "OPTIONAL EQUIPMENT"**

- **Infrared Microprocessor Control** (factory installed only)
- **Hydronic Heat** (factory installed)
- **Low Ambient Control** – consisting of a fan cycle switch and a crank case heater, for cooling operation down to 32° F (field installed).
- **Hard Start** (field installed)
- **Sea Coast Style Copper/Copper Coils** – protects against corrosion due to acids, solvents and salt
- **Fresh Air Duct Collar**
- **Wall Thermostat**



Comfort Where It Counts.

5780 Success Drive, Rome, NY 13440
Phone: 1-800-228-9364
FAX: 1-800-232-9364
Email: emi@enviromaster.com